



CHEMICAL SANITIZING UNDERCOUNTER GLASSWASHER

GL-X

Low Temperature Undercounter Glasswasher



FEATURES

- 30 racks per hour.
- Large 11-1/4" door opening.
- Economical to operate. Uses only 1.7 gallons of water per cycle.
- All stainless steel construction assures long life and years of trouble free operation.
- Unique spray arm system features upper and lower stainless steel wash arms with reinforced end caps.
- Built-in chemical pumps and deliming system assures proper chemical usage.
- Convenient to service "Works-in-a-drawer". All electrical components are attached to a sliding drawer for easy access and service.
- Instant start for simple operation.
- Pumped drain allows for flexible installations. No floor drain required.
- Wash tank sustainer heater keeps water at proper temperature between loads.
- Stainless Steel Legs 4" (set of 4).
- Uses standard 19-3/4"-19-3/4" racks.

CMA MODEL: GL-X

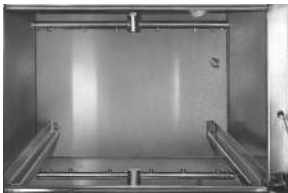

Upper and lower rotating wash arms guarantee excellent results.



"Works-in-a-drawer." All electrical components are attached to a sliding drawer for easy access and service.



Built-In Hot Water Assurance System provides hot water every cycle.

AVAILABLE OPTIONS

- Low Chemical Alarm
- Drain Board
- CMA TEMP-SURE

CMA MIZER
Registered Trademark





GL-X
Chemical Sanitizing
Glasswasher

WARNINGS:

- Plumbing connections must be made by a qualified service company who will comply with all available Federal, State, and Local Health, Plumbing and Safety codes.
- CMA recommends utilizing a water softening system to maintain water hardness measurements of 3.5 gpg (grains per gallon) or less. This will assure maximum results and optimum operation of the dishmachine.

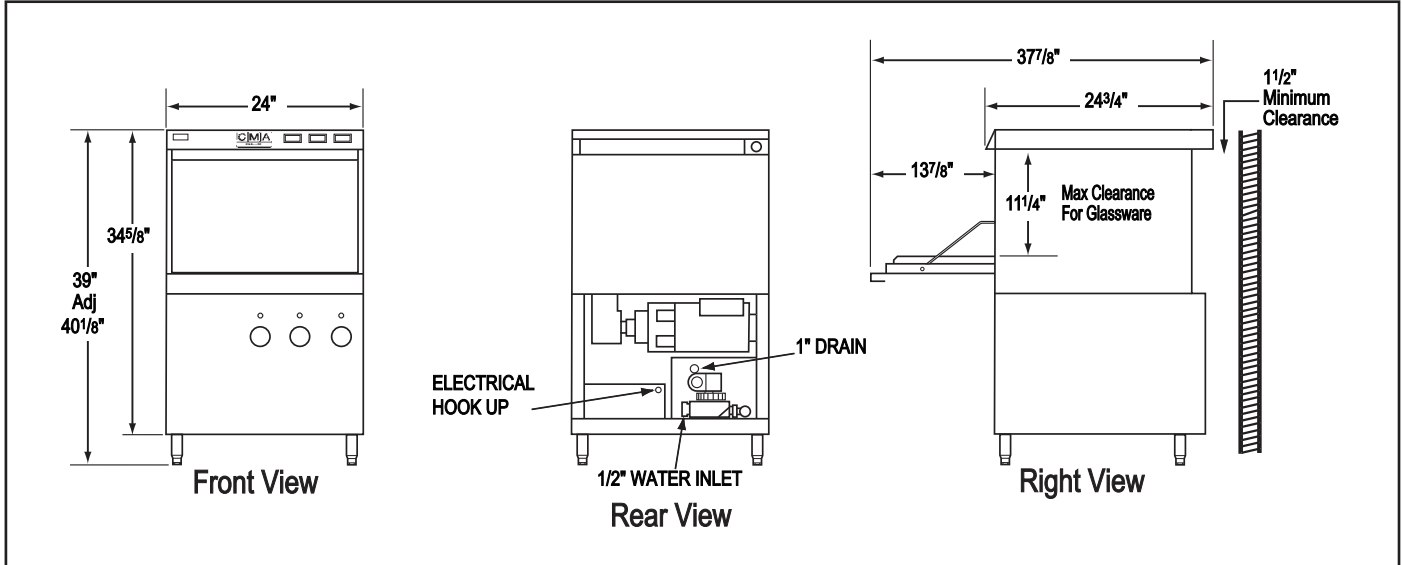

Specifications:

MODEL GL-X	USA	METRIC	USA	METRIC
OPERATING CAPACITY RACKS PER HOUR	30	30		
OPERATING CYCLE WASH TIME-SEC RINSE TIME-SEC DWELL/TIME-SEC TOTAL CYCLE TIME	58 32 30 120	58 32 30 120		
WASH TANK CAPACITY	1.7 GAL.	(6.45 L)		
WASH PUMP CAPACITY	35 GPM	(132 LPM)		
MINIMUM TEMPERATURE REQUIRED WASH TEMP.	120°F	(50°C)		
WATER CONSUMPTION PER RACK PER HOUR WATER INLET DRAIN	1.7 GAL. 51 GPH 1/2" 1"	(6.45 L) (193 LPH) (1.27 cm) (2.54cm)		
WASH PUMP MOTOR HP			1	1
DIMENSIONS DEPTH WIDTH HEIGHT MAXIMUM CLEARANCE FOR GLASSWARE			24-3/4" 24" 39"-40-1/8" 11-1/4"	(63cm) (61cm) (99-102cm) (28.57cm)
STANDARD DISHRACK DIMENSIONS			1 20" x 20"	1 (50.8 X 50.8cm)
ELECTRICAL RATING			VOLTS 115	AMPS 16
APPROXIMATE SHIPPING WEIGHT SHIPPING DIMENSIONS			202# PALLET & BOX @ 29" X 28" X 42"	(92kg)

Summary Specifications: Model GL-X

The GL-X glasswasher is a low temperature undercounter dishmachine designed to produce sparkling clean glassware utilizing our unique Hot Water Assurance System. The GL-X is easy to use, fast and efficient, while conserving water, energy and chemicals. Built-in sustainer heater provides continuous 130°F hot water every cycle. The GL-X is constructed entirely of stainless steel and is equipped with an integrated chemical delivery system. The GL-X incorporates a pump purging system that improves results by eliminating soil and chemical carryover during rinse cycle.

Advisory: CMA does NOT endorse "Tankless On-Demand" water heaters for use on CMA Dishmachine products. CMA DOES endorse, and highly recom-mends, the standard "tank" style water heaters, sized properly to handle each particular facility with their water heating requirements.



CMA Dishmachines 12700 Knott Street Garden Grove, CA 92841 • 800-854-6417 • 714-898-8781 • Fax: 714-895-2141 • www.cmadishmachines.com

CMA reserves the right to modify specifications or discontinue models without prior notification.

© 3-2020 CMA, Inc.

an Ali Group Company



The Spirit of Excellence