



CHEMICAL SANITIZING ENERGY SAVING SINGLE RACK DISHWASHER

E-EXT

Low Temperature
Energy Saving Dishwasher



MODEL: E-AH-EXT

MODEL: E-C-EXT



CMA MODEL: E-EXT



Low Chemical Alarm



Temp-Sure
Requires a separate 208-240v
3 phase 40 amp power supply

FEATURES

- 40 racks / 160 covers per hour.
- 20-1/2" Door opening for maximum clearance.
- Economical to operate. Uses only 1.01 gallons of water per cycle.
- All stainless steel construction assures long life and years of trouble free operation.
- Unique spray arm system features upper and lower stainless steel wash arms with reinforced end caps.
- Top mounted controls include built-in chemical pumps and deliming system for dealing with scale.
- Auto start/stop makes operation safe and easy.
- New integrated scrap tray prevents food soil from entering drain system.
- Airgap fill system.

CONVERTIBLE CORNER TO
STRAIGHT AND STRAIGHT TO
CORNER.

AVAILABLE OPTIONS

- Alternative cycle times
- Solid/Powder Dual Bowl Dispenser
- 3 Door Open
- Stainless Steel Tables
- Alternative Cycle Times
- Alternative Electrical Available
- Slant Shelf 21" x 42"
- Stainless Steel Scrap Trap in lieu of Poly Pro

**CMA
MIZER®**
Registered Trademark





MODEL E-EXT

LOW WATER MACHINES

WARNINGS:

- Plumbing connections must be made by a qualified service company who will comply with all available Federal, State, and Local Health, Plumbing and Safety codes.
- CMA recommends utilizing a water softening system to maintain water hardness measurements of 3.5 gpg (grains per gallon) or less. This will assure maximum results and optimum operation of the dishmachine.

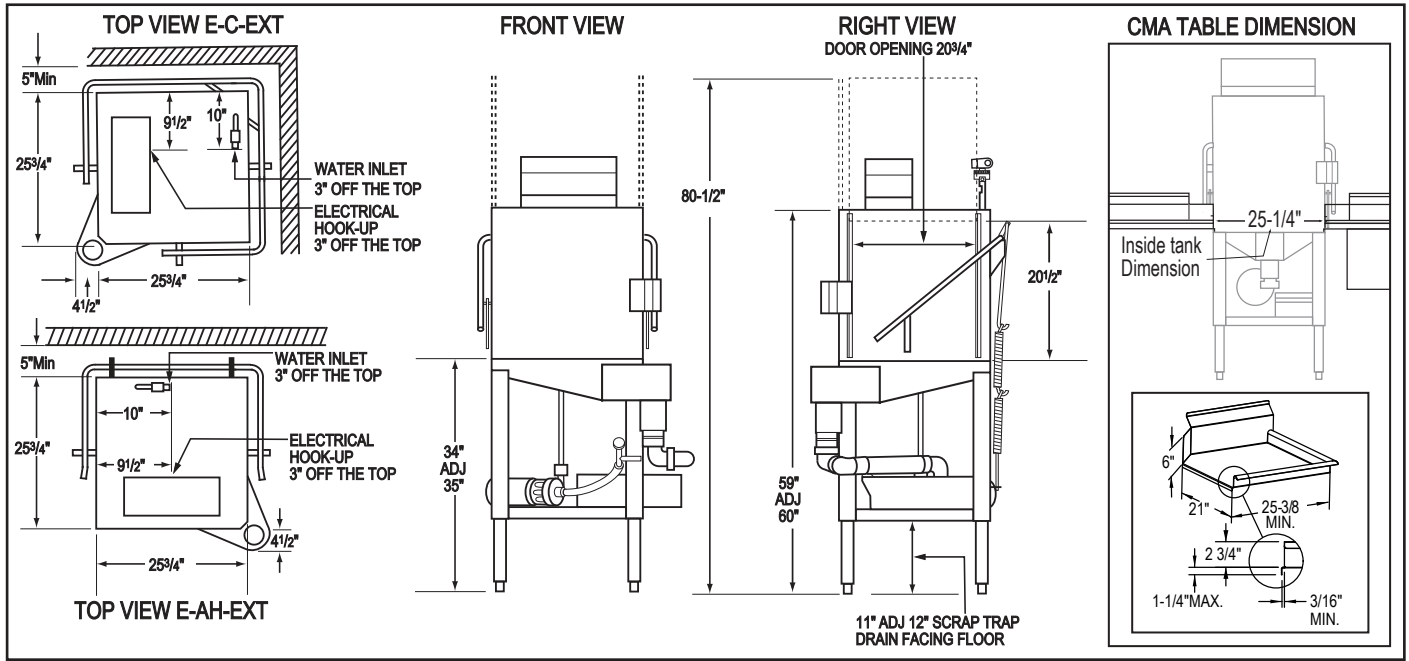

Specifications:

MODEL E-EXT	USA	METRIC	USA	METRIC
OPERATING CAPACITY RACKS PER HOUR (NSF RATED)	40	40	WASH PUMP MOTORS HP	1
OPERATING CYCLE WASH TIME-SEC RINSE	45	45	DIMENSIONS DEPTH	25-3/4" (65.4cm)
TIME-SEC DWELL	30	30	WIDTH (OUTSIDE DIMENSION)	25-3/4" (65.4cm)
TIME-SEC TOTAL	15	15	TOTAL HEIGHT WITH DOORS OPEN	80-1/2" (204cm)
CYCLE TIME	90	90	STANDARD TABLE HEIGHT	34" (86cm)
PUMP CAPACITY	52 GPM	(197 LPM)	MAXIMUM CLEARANCE FOR DISHES	20-1/2" (52cm)
OPERATING TEMPERATURE REQUIRED	120°F	(49°C)	STANDARD DISHRACK DIMENSIONS	1 20" x 20" (50.8 x 50.8cm)
RECOMMENDED	140°F	(60°C)	ELECTRICAL RATING	VOLTS 115
WATER CONSUMPTION PER RACK	1.01 GAL.	(3.8 L)	APPROXIMATE SHIPPING WEIGHT	E-AH EXT/E-C EXT 262# (118.8kg)
PER HOUR	40.4 GPH	(152.9 LPH)	E-3D EXT 264# (119.8kg)	
WATER REQUIREMENTS WATER INLET	1/2"	(1.27cm)	SHIPPING DIMENSIONS	PALLET & BOX @ 41" X 41" X 80"
DRAIN-I.P.S.	2"	(5.1cm)		

Summary Specifications: Model E-EXT

CMA Energy Miser model E-EXT low temperature, chemical sanitizing commercial dishwashers meet ETL, UL, and CUL sanitation and construction standards WITHOUT the use of BOOSTER or TANK HEATERS. The model E-EXT is constructed entirely of stainless steel. Each unit automatically washes, rinses and sanitizes utensils in standard 19-3/4"-19-3/4" racks. Units come with standard upper and lower stainless steel wash arms. **Note: This machine does not have built-in heaters, therefore produces no steam.**

- Available Models:**
- E-AH Straight EXT
 - E-C Corner EXT
 - E-3-Door EXT

Advisory: CMA does NOT endorse "Tankless On-Demand" water heaters for use on CMA Dishmachine products. CMA DOES endorse, and highly recommends, the standard "tank" style water heaters, sized properly to handle each particular facility with their water heating requirements.



CMA Dishmachines 12700 Knott Street Garden Grove, CA 92841 • 800-854-6417 • 714-898-8781 • Fax: 714-895-2141 • www.cmadishmachines.com

CMA reserves the right to modify specifications or discontinue models without prior notification.

an All Group Company



The Spirit of Excellence

© 3-2020 CMA, Inc.